

EM1/5...250E/2c/H Series

Servo Electromechanical High Temperature Testing Machines



MICROTEST, S.A.

Instruments and Equipments for Materials Testing
(+34) 91 796 33 32 www.microtest-sa.com



DESCRIPTION

The **EM1/5...250E/2c/H Series** are a modified version of EM1/5kN...250kN/FR stand-alone vertical axial universal testing machine (UTM). Microtest EM1/5...250E/2c/H Series Servo Electromechanical High Temperature UTMs have been designed and engineered for high temperature testing applications at static and quasi static loading rates. The load frame capacity can vary between **5 kN** and **250 kN** as standard. Other load capacities can also be supplied upon request. The standard testing configuration includes **pull/push rods**. This configuration makes use of interchangeable testing accessories (specimen holders for tensile testing, platens for compression testing, clevis grips, etc.) made from heat resistant steels (for temperatures up to 700 °C) or nickel based superalloys (for temperatures up to 1200 °C). The pull/push rods are also made from heat resistant steels or nickel based superalloys. High temperature pull/push rods are sufficiently long to accommodate the furnace during high temperature tests and perfectly suitable for connection to high temperature testing accessories.

Its compact design consumes a minimal amount of laboratory space while performing mechanical tests (tension, compression, flexure, etc.) on a variety of materials. It is also possible to adapt this type of universal testing machines for other type of high temperature tests. Possible testing applications includes:

- Room/high temperature static tests such as tension, compression, flexure/bend, shear, etc. in position, load and strain control modes (STANDARD)
- High temperature creep, creep crack growth and stress relaxation tests (OPTIONAL)
- Accelerated stress rupture tests at high temperature (OPTIONAL)
- High temperature low cycle fatigue (LCF) tests in tension, compression and through zero (OPTIONAL)

Rigid construction with **central ball screw** (single screw drive) and **two steel guide columns** provides precise alignment during testing at high temperature. Guide columns are treated and hard-chrome plated for extended life and durability. **Two load frame constructions** are available: **standard twin column frame (2c option)** and **optional four column frame option (4c option)**.



FEATURES

- Floor standing (STANDARD) or tabletop (OPTIONAL) vertical axial load frame
- Dual column load frame with a central ball screw, featuring excellent stiffness and precise crosshead guide for superior performance and more accurate and reliable test results
- Base mounted or upper crosshead mounted servo electric actuator
- Precision alignment
- Free from self-induced shocks and vibrations
- Ergonomic working height and design
- Modern and compact load frame: a small footprint and space-saving load frame design pack a powerful testing system into less lab space
- Advanced load cell technology for faster testing and reduction of inertial errors
- Full software control
- Automatic recognition/calibration of load/strain transducers and other auxiliary equipment
- A wide range of standard and custom equipment options
- Compatible with various types of specimen grips/fixtures/adaptors, environmental chambers, video extensometers and other auxiliary accessories
- Compatible with resistant, induction and infrared furnaces
- Single phase electrical power supply of 220/240 VAC, 50/60 Hz or three phase electrical power supply of 380/415 VAC, 50/60 Hz, depending on the proposed specifications and included testing accessories
- Totally pre-calibrated for the scope of testing performance, precision and accuracy
- Full CE compliance



FURNACE

The standard applications for high temperature tests includes a **1-zone** or **3-zone resistance/induction/infrared furnace** for a temperature range from **200 °C** (or even lower) up to **900 °C, 1000 °C, 1100 °C or 1200 °C**. Automatic temperature control is carried out by means of a state-of-the-art digital programmable temperature **Eurotherm** or **Watlow** controller. For 3-zone furnaces, every zone in the furnace has its own heater that can be controlled through a furnace thermocouple (type K/N/R/S) and a specimen thermocouple (type K/N/R/S) in dual loop control (typically cascade control). This configuration leads to a high temperature stability (less than ± 2 °C) and a precise long term temperature control, without overshooting. Another set of three protection thermocouples is used to protect the furnace from accidental overheating.

The standard furnace features a tubular design, concentrically placed along the test axis. The furnace can be moved up/down to adjust the available space for different types of tests.

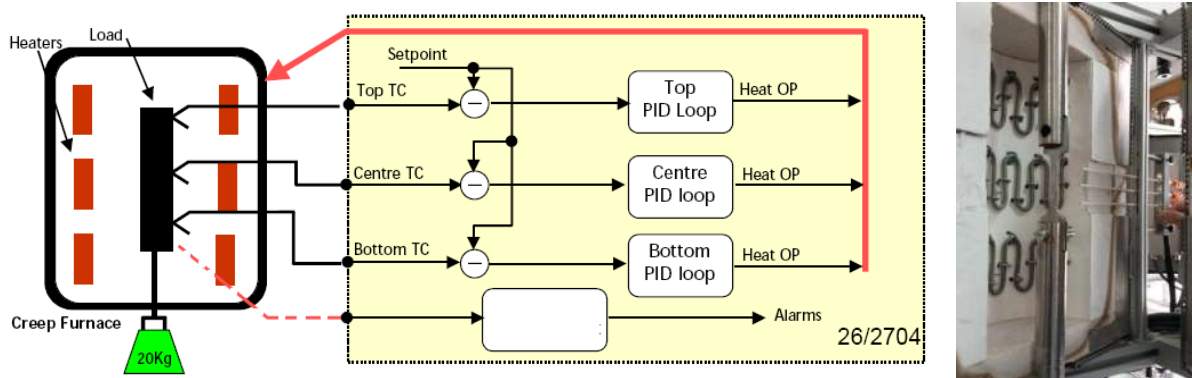

The furnace isolation is provided by means of refractory ceramic fiber, complying with the European standard for fiber solubility (Commission Directive 97/69/EC). The machine frame has been designed to accommodate the furnace. It uses an extra-large testing area; and the vertical clearance allows an easy management of the furnace. Environmental chambers can also be supplied under demand.



SCM3000 TESTING SOFTWARE

The EM1/5...250E/2c/H Series Servo Electromechanical High Temperature Testing Machines are operated by **Microtest SCM3000 testing software** that enhances the features and capabilities of these machines for conducting **high temperature tests** on a wide variety of materials and components in **automatic** and **manual** control modes. The SMC3000 software is a Windows based, easy-to-use, flexible and powerful modular testing software with advanced control and safety features, fully configurable graphical user interface composed of multiple live data displays (up to 12) and live plotting, zooming and exporting for the measured values, test results and calculations. The SCM3000 testing software comprises **5 modules**, including **CONFIGURATION**, **METHODS EDITOR**, **TEST CONTROL**, **DATA ANALYSIS (results editor)** and **USER MANAGEMENT**. Each designed for a specific purpose, these modules provide utmost flexibility to modify the preset standards-compliant test methods or create new ones, design complex test sequences, run tests, analyze data and report results using standard or custom-built templates (containing test data, graphs, tables, lists, etc.).

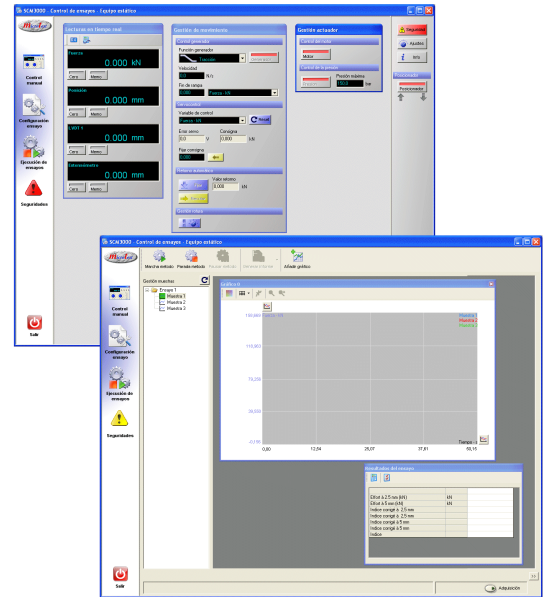

MICROTEST HIGH TEMPERATURE AXIAL EXTENSOMETER (HT-EXT)

- Rod-in-tube construction
- Designed for high temperature testing
- Designed for grooved specimen and specimen holders
- Interchangeable attachments for different types of specimen geometries/dimensions
- Single or dual gauging platforms with adjustable gauge lengths
- Adaptable for different types of displacement transducers (such as Heidenhain 1278 linear digital displacement gauge)
- Resolution: 0.001 mm (STANDARD) or 0.0001mm (OPTIONAL), measuring range up to 12 mm
- Maximum Temperature: 1000 °C / 1200 °C (SHT-EXT version)



SPECIFICATIONS

LOAD FRAME

- Designed to be suitable for ambient and elevated temperature tests
- High stiffness load frame with 2 or 4 guide columns and a central ball screw servo electromechanical actuator
- Base mounted (movable lower crosshead and fixed upper crosshead) or upper crosshead mounted (movable upper crosshead and fixed lower crosshead) servo electromechanical actuator
- Load Capacity: 5 kN, 10 kN, 50 kN, 100 kN and 250 kN (or other capacities upon request)
- Chrome-plated steel guide columns
- Frame Stiffness: 200 kN/mm to 700 kN/mm (or higher stiffness upon request)
- Precise axial alignment by precision crosshead guiding and special seating load train
- Requires no special base or foundation
- Includes vibration isolation legs with dampers under the load frame
- High resolution crosshead position and load measurement providing superior test control
- Column spacing: ≥ 300 mm, depending on the required specifications and accompanying testing accessories
- Vertical test space: sufficient to accommodate intended testing applications and accompanying testing accessories
- End limit switches: factory fixed
- Alarm switches: computer adjustable
- Integrated high temperature controller

SERVO ELECTROMECHANICAL ACTUATOR

- Central ball screw (single screw drive)
- Fully digital closed loop servo control by Microtest SCM3000 digital control electronics
- Control modes: position and load as standard and strain upon request
- Operation: directly from frontal control panel using Up/Down push buttons or through the Test Control Module of SCM3000 testing software
- Stroke range: 75 - 250 mm (or more upon request)
- Test speed range: 0.01 mm/min to 200 mm/min (other ranges upon request)
- Test speed resolution: 0.01 mm/min ()
- Manual crosshead controls: a set of up/down buttons on the frontal control panel provides a simple interface for operating the actuator

LOAD CELL

- Strain gauge type load cell suitable for tensile and compressive loads
- Wide measurement range from 500 N (or even lower) up to 250 kN
- Auto recognition and calibration
- High axial and lateral stiffness
- High resistance to unfavorable influences such as transverse forces
- Excellent linearity through tension and compression
- Load Accuracy: ISO 7500-1 Class 0.5
- Over load protection: 150% of the read capacity without permanent zero shift
- Meeting or exceeding the requirements of highest applicable testing standards, including ISO 75001-1, ASTM E4, EN10002-2, DIN 51221 and JIS B 7721/7733

DISPLACEMENT MEASUREMENT

- High precision optical incremental digital encoder
- Full range crosshead travel
- Position display resolution : ≤ 0.001 mm (1 μ m)
- Position measurement resolution : typically ≤ 0.0001 mm (0.1 μ m)
- Computer actuated return to selectable position

ACCESSORIES

- A wide variety of options, including but not limited to resistance/induction/infrared furnaces, environmental chambers, extensometers, grips, fixtures, compression platens, etc.

OTHER REQUIREMENTS

- Supply power: 220/240 VAC 1-Phase or 380/415 VAC 3-Phase, depending on the accompanying testing accessories
- Adaptable to other local voltage requirements
- For computer specifications, check the requirements for SCM3000 testing software



MICROTEST, S.A., C/ Valle de Tobalina, 10, 28021 Madrid, Spain
Tel.: +34 91 796 33 32 - Fax: +34 91 796 32 36 | microtest@microtest-sa.com - www.microtest-sa.com