

## HT-ST-1200 Model

### 3-Zone Split-Type Tubular Furnace



## OVERVIEW

- The standard application for high temperature tests includes a **3-zone** (also **1-zone** upon request) **vertical tubular split furnace** for a temperature range from typically **200 °C** (or even lower) to **1200 °C** (can be increase up to **1800 °C**) with a state-of-the-art **Eurotherm 2604 or 2704** digital programmable temperature controller.
- Stainless furnace cover and asbestos-free insulation material (bio-soluble fibre).
- **Kanthal** heating element
- Min. / Max. temperature: **200 °C** (or even lower) / **1200 °C** (also **1000 °C, 1100 °C or 1800 °C** upon request) on the sample
- Power requirement: **single phase, 230 VAC, 50 Hz** (other voltages under request).
- Every zone in the furnace has its own heater that can be controlled through a type K (or R, J or S) thermocouple and a sample thermocouple type K or S (total of 3 thermocouples at the specimen) in a dual loop process (typically cascade control) with standard color coded connectors and cables. This configuration leads to a high temperature homogeneity on the sample and stability (better than **±2 °C**, typically **±1 °C** for both cases) and a precise temperature long term control, without overshooting. The uniform temperature zone (better than **±2 °C**, typically **±1 °C**) is at the middle of the furnace and at least **100 mm**.
- Another set of three thermocouples is used to protect the furnace from accidental overheating (limiting over temperature control). The system includes additional individual controllers for these limiters, with a first limit to set the power down to zero for the corresponding zone and a second one to stop the whole system for security.
- The **2604 or 2704 Eurotherm controller** Integrate a sophisticated PID Control-Algorithm for a precise Temperature along specimen and to prevent temperature overshooting. Each zone is individually adjustable for power to attain temperature uniformity on the specimen length. Temperature control setting can be from **200 °C** (or even lower) to **1200 °C** (or other values upon request). Thermocouple break protection is available. Cold junction compensation - Automatic (internal) and 45 and 50 °C (external user selectable).
- For each zone, the power is driven by Eurotherm Thyristors. The control unit system includes fuse holders and fuses and furnace over temperature shutdown relay and contactors.
- The controller can operate in a stand-alone mode (including digital display of set and process temperature values) or be operated by PC. The MICROTEST **SCM3000 software** allows this operation including displaying and recording of temperatures as test data.
- The furnace is a **split type design with 3 heating zones**, adapted to machine pull rods, concentrically placed along the test axis. Top and bottom finish insulation is in low thermal conducting (low 'K' factor) vacuum cast ceramic fibre insulation to provide minimum heat loss, high temperature capability and for rigid structure.
- Ceramic end caps at the top fit snugly around pull rod and the bottom end cap have cut out for extensometer arms and pull rod and reduce the heat loss at this points. Bottom side end cap are secured with quick retainer clamps to keep the tight fitting of the above thermal insulation boards to seal the leakages.
- The furnace can be adapted to accommodate different testing machine frames. The furnace is mounted on the machine frame such that the position of the furnace is normally adjustable vertically.
- Operating Voltage: single phase, **230±10 % VAC, 50/60 Hz** or 3 phases, **400 VAC, 50/60 Hz** (under demand). Furnace power cables of suitable length are included.
- The furnace dimensions are usually adapted to the end user testing requirements and individual testing applications.

- To achieve a suitable low external surface temperature, an extra cover in stainless steel acts as thermal shield for operator protection: external temperature < 50 °C.
- Extensometer slot(s), thermocouple slot(s), thermocouple port, pull rod ports among other entrances and cut-outs



Specifications	Typical Values	<b>MOUNTING BRACKETS</b> <i>Depending on the application and type of machine frame, the furnace is supplied with the mounting brackets, attachments and fittings to support the furnace during the tests and allowing it to be retired out of the testing area when not in use.</i>
Max. furnace temperature	≥ 1300 °C (also other values upon request)	
Max. temperature on the sample	1200 °C (also 1000 °C, 1100 °C or 1800 °C upon request)	
Min. temperature	200 °C (or even lower)	
Heating rate	10-20 °C/min	
Inner diameter (*)	90 - 120 mm	
Outer diameter (*)	> 360 mm, typically 400 mm	
Heating zone length (*)	150 - 350 mm	
Total furnace height (*)	400 - 480 mm	
Heating zones	3	
Nominal voltage	230 ±10% VAC	
Nominal power	2.5 to 3.6 kW	
Temp. homogeneity on sample	≤ ±1 °C (steady state)	
Temp Stability	≤ ±1 °C	
Uniform temperature zone (at the middle of the furnace)	≥ 100 mm	

(\*) Typical values. Final dimensions depends on the application



## TEMPERATURE CONTROLLER UNIT

The temperature controller unit includes a **2604** or **2704 Eurotherm digital temperature controller**, the power unit and communication to the machine control unit by USB port. The **2604** or **2704 Eurotherm temperature controller** integrate a sophisticated PID Control-Algorithm for a precise Temperature along specimen and to prevent temperature overshooting. Each zone is individually adjustable for power to attain temperature uniformity on the specimen length. Temperature control setting on test specimen can be from **200 °C** (or lower) to **1200 °C** (also other values upon request). Thermocouple break protection is available. Cold junction compensation Automatic (internal) and 45 and 50 °C (external user selectable). For each zone, the power is driven by Eurotherm Thyristors. The control unit system includes fuse holders and fuses and furnace over temperature shutdown relay and contactors. The controller can operate in a stand-alone mode (including digital display of set and process temperature values) or be operated by PC. The MICROTTEST SCM3000 software allows this operation including displaying and recording of temperatures as test data.

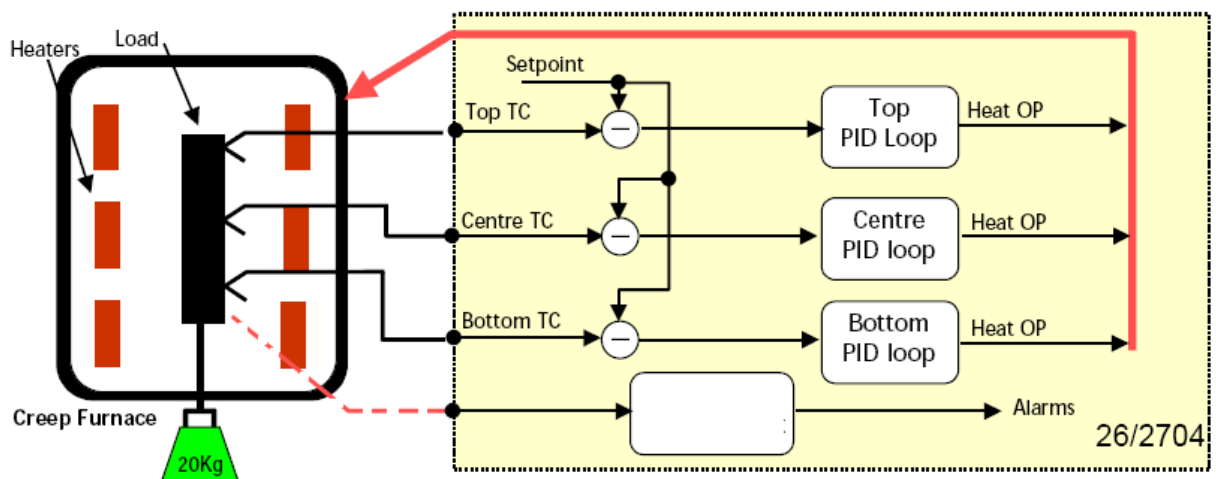
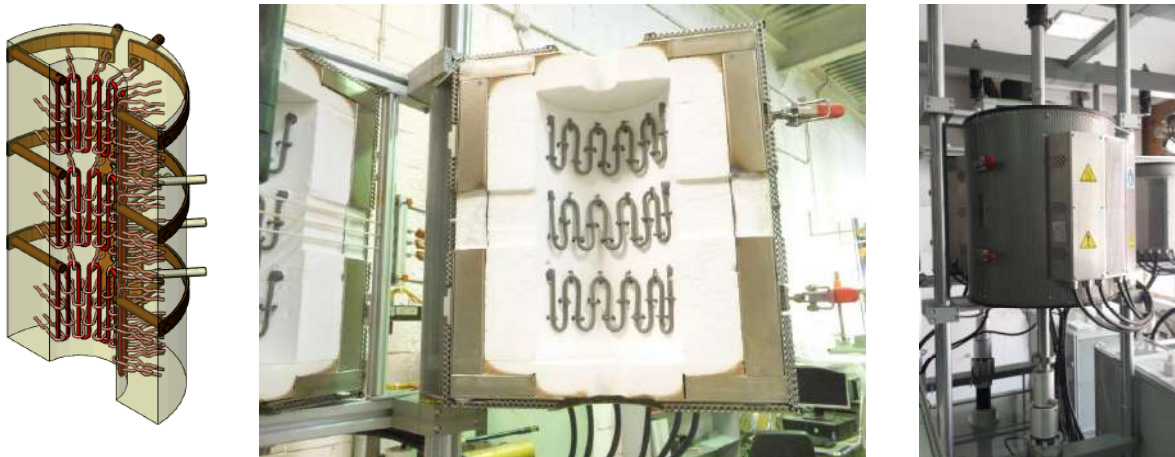



### PULL RODS AND ADAPTERS

A variety of pull rods and specimen adapters are available to accommodate various specimen geometries. They are made of special high-temperature materials for durability and ease of use. High Temperature Pull Rods and adapter are in Inconel 718 or 713C or other Ni-based high temperature alloys.

Specimen Holders are easily removed from the pull rods to allow rapid interchange of flat, threaded, or button head specimen shapes. One of the standard configuration is applied for threaded samples (M6, M8, M10,...). This configuration makes use of interchangeable threaded couplings made in high temperature resistant NI-base alloy or super-alloy and defined for every type of threaded sample.

Other types of grips are made of Inconel-713C or 718 to fix into pull rods for high temperature tensile tests of samples. For button head specimens, collars to hold the specimens can also be supplied. Other adapters: pin and clevis specimen holders for mounting of flat specimens with a mounting hole diameter, threaded-end specimen holders, special wedge grips, etc. in high temperature alloys.



### OTHER MICROTEST FURNACES FOR TESTING

MICROTEST manufactures a complete line of different laboratory furnaces for different testing requirements and individual testing applications.

From medium temperature furnaces (150 – 250 °C) to high temperature furnaces (1800 °C, with heating element of MoSi<sub>2</sub>), all MICROTTEST furnaces and ovens are constructed using high-quality stainless steel exteriors and efficient ceramic thermal isolation. They are designed to work with material testing systems of all types, such as **Tensile Testing, Fatigue Testing, Compression Testing, Creep Testing** or **Tribological Testing**, and can be manufactured for new OEM systems or for retrofitting and integration into an existing system.

MICROTTEST Laboratory furnaces and ovens can be designed for horizontal or vertical operation and optionally supplied with various types of mounting brackets or stands as well as ports for atmosphere introduction. MICROTTEST Furnaces can be customized to the end user individual specifications.



**MICROTTEST, S.A.**, C/ Valle de Tobalina, 10, 28021 Madrid, Spain

Tel.: +34 91 796 33 32 - Fax: +34 91 796 32 36 | [microtest@microtest-sa.com](mailto:microtest@microtest-sa.com) - [www.microtest-sa.com](http://www.microtest-sa.com)